

13CDU

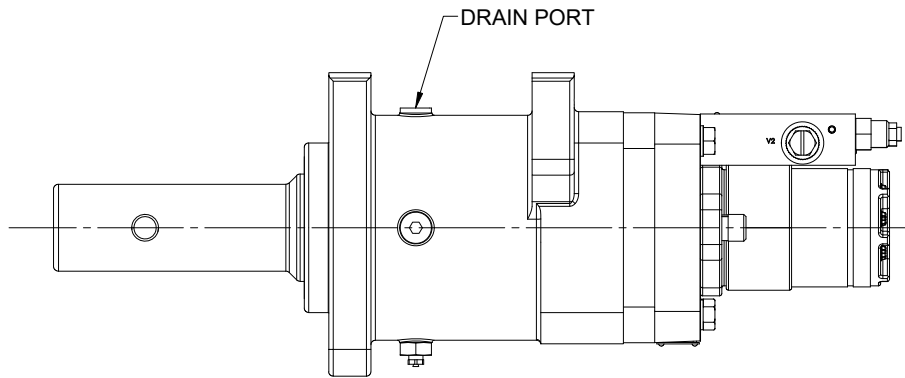

INLET & OUTLET PORTS
SAE #8 O'RING

$\phi 21/32$ THRU
TYP (4) PLCS

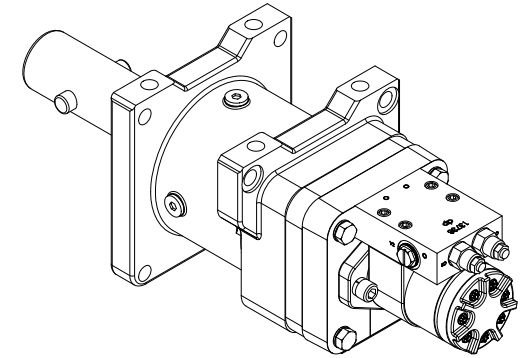
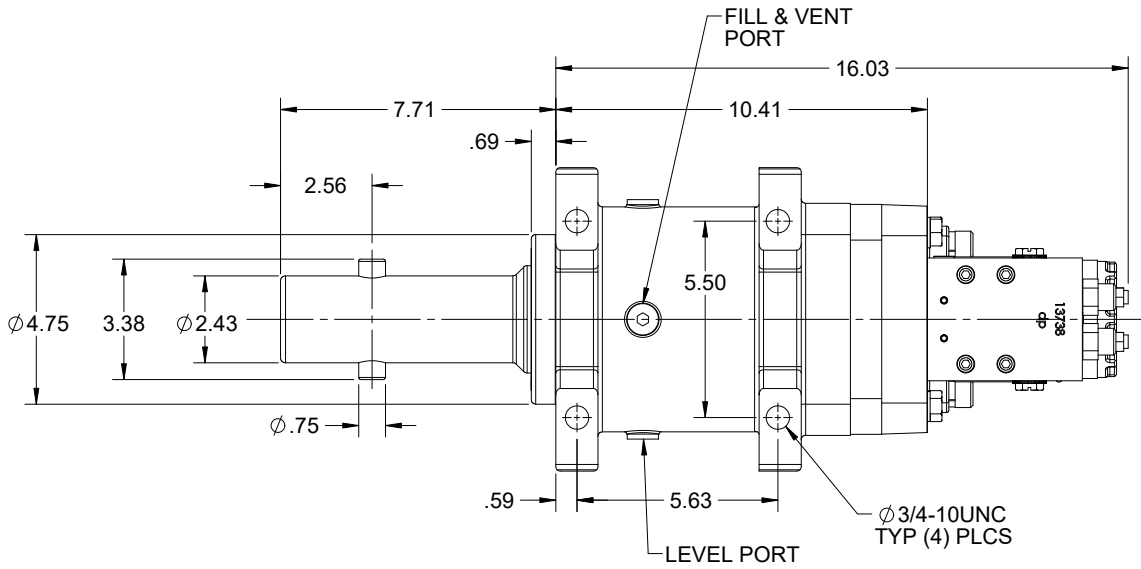
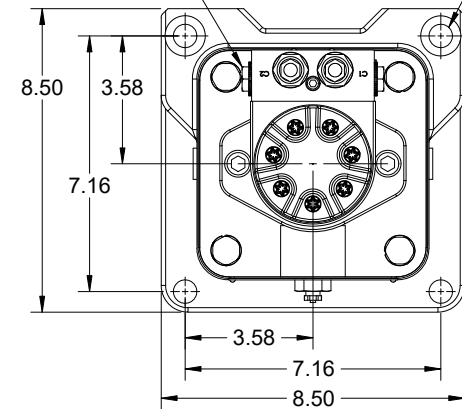

16CDU

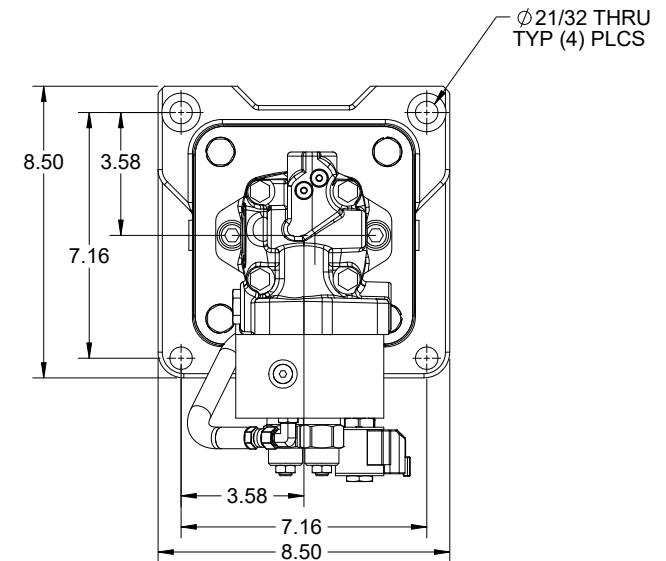
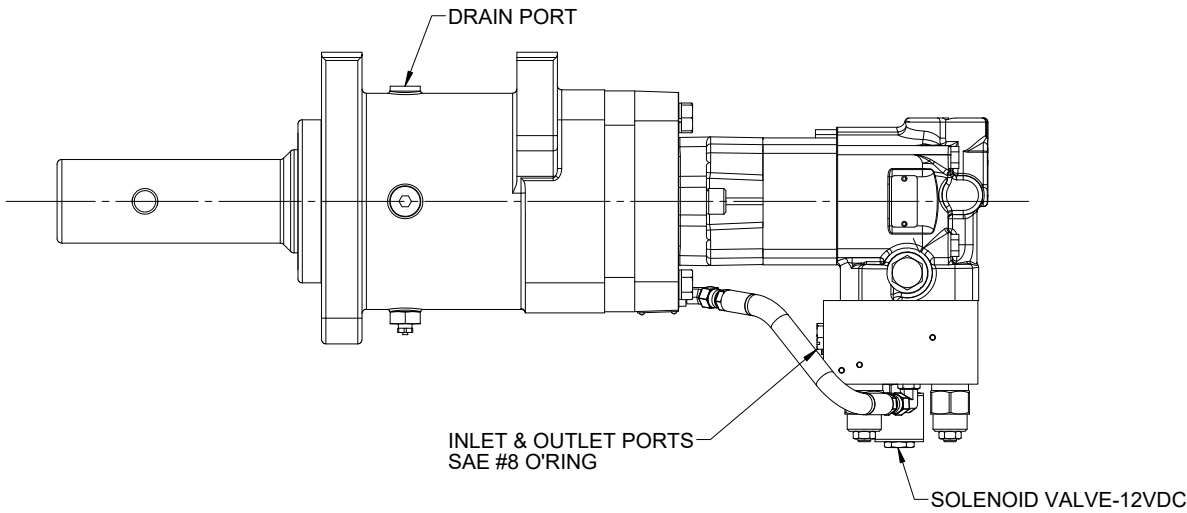
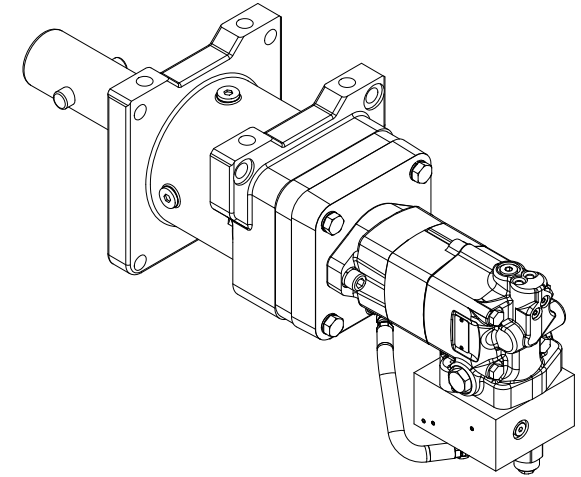
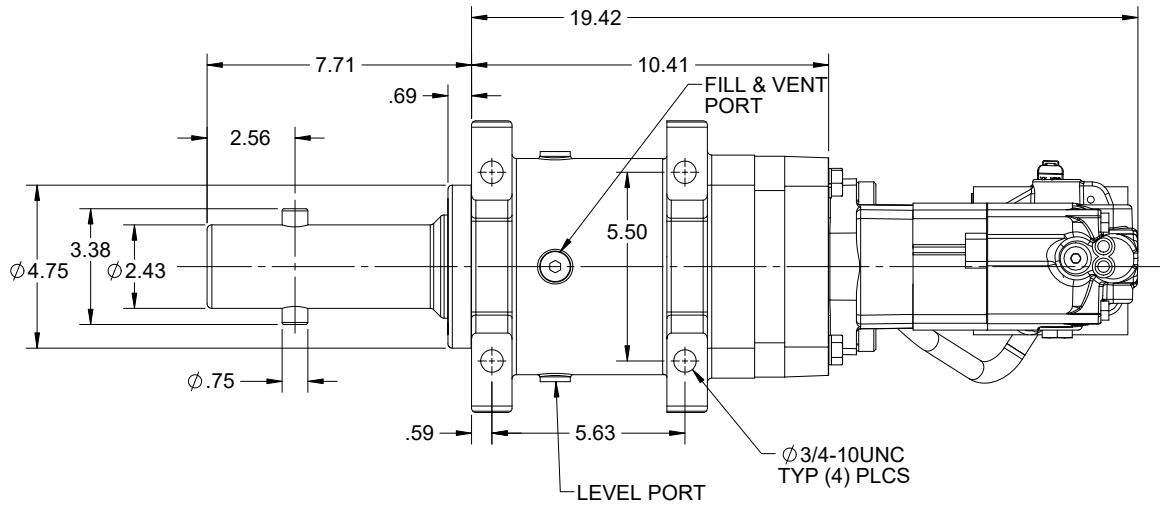

24CDU

