



TWG
a **DOVER** company

MARINE



Transforming the way you work

INNOVATIVE SOLUTIONS THAT CHANGE WHAT IS POSSIBLE

Tough jobs demand today's most advanced equipment and technology. Reputations depend on it. And nowhere is quality, innovation, and state-of-the-art performance more important than in the marine sector—where workers need to rely on their equipment, day in and day out.

At TWG, we develop the tools, technology, and equipment to help transform your work process and environment—so you can get the job done more efficiently and effectively. Our integrated systems connect equipment, analyze data, and deliver real-time insights that reduce downtime and improve productivity. By combining Artificial Intelligence and the Industrial Internet of Things, we'll help you unleash powerful new levels of performance. Interact with our desktop dashboard via our web portal or mobile app with voice recognition software—giving you 24/7-access to the information you need, including instant technical support, troubleshooting help, and over 10,000 documents.

A leading producer of winches, hoists, slewing ring bearings, swing drives, electronic monitoring systems, and more, TWG is part of the Dover Corporation—a global manufacturer with annual revenues over \$7 billion. With more than a million units installed, we offer a vast range of essential parts and products across seven model lines: DP Winch, Gear Products, Greer, LANTEC, Pullmaster, Tulsa Winch, and RUFNEK.

Smooth sailing

MARINE INDUSTRY SOLUTIONS THAT MINIMIZE DOWNTIME

From commercial fishing, to oceanography, to maintaining essential waterways, the marine sector is made up of some of the toughest industries in the world. That's why it's crucial that manufacturers of today's marine equipment choose components with a trusted reputation for quality and dependability—ones that minimize downtime while maximizing productivity.

Purpose-built for the marine market, our products feature corrosion resistant sealing surfaces and all rotating components completely enclosed in an oil bath. In addition, our marine products can be made in accordance with many industry standards including American Petroleum Institute (API), American Bureau of Shipping (ABS), and Det Norske Veritas (DNV).

Used in a wide variety of marine applications, TWG products are custom designed for power, efficiency, and long-lasting reliability. From winches and hoists for fishing boats, to hydraulic pump drives for dredges and tugboats, our cutting-edge solutions are engineered to perform under pressure. To keep working under the harshest conditions, TWG products stand up to extreme temperatures, wind, and salt water. Our durable, hard-working products deliver superior performance—and they break down less often, so operators can achieve peak productivity, day in and day out.

With industry-leading quality, technology, and design, TWG real-time electronic monitoring systems offer innovative custom solutions that meet the requirements of the marine sector's most demanding manufacturers.





dovertwg.com



Reel in better results

FISHING & RESEARCH APPLICATIONS

Out on the water, time is money. The last thing anyone wants is to return to shore for equipment repairs. That's why TWG winches, hoists, swing drives, and other components are designed tough—and keep running long after others give out.

Known for their durability, our products feature smooth lowering control and high speed rapid reverse to retrieve and let out nets faster—saving operators time and money. To withstand the elements, we use corrosion resistant sealing surfaces, marine grade coatings, and all rotating components are totally enclosed in an oil bath. Purpose-built for marine environments, our model lines also feature heavy-duty materials—providing the perfect balance between power and efficiency—so operators can do more in less time.

When it comes to efficiency, you'll appreciate that our products not only provide long lasting trouble-free service, but require less maintenance, too. To meet your specific needs, we offer multiple drum sizes, free fall, and rapid reverse features—along with a wide range of complete systems that can be customized for your specific requirements. As a single source for your gearing needs, TWG products meet OSHA rotation and direction requirements for both wired and wireless applications. Crane hoists can be custom designed for your needs and API, ABS, and DNV requirements. Our integrated electronic monitoring systems and mobile app will also keep things running smoothly with immediate, 24/7 interactive feedback, technical assistance, and drawings.

INDUSTRY-LEADING PERFORMANCE AND RELIABILITY.

WINCH

- 1,000-300,000 lbs (4.4 to 1334.4 kN) line pull
- Air, hydraulic, or manual clutch
- Fairleads and cable hold down options

HYDRAULIC PUMP DRIVE

- 15 models with multiple gear ratios
- Up to 1,200 HP (894 kW) and 8 pump pads to SAE standards
- Multiple input options including a torsional coupling

SLEWING RING BEARING

- Single and double row ball bearings up to 6 ft (1.8 m) diameter
- Bending moment capacity up to 3 M ft-lbs (4 MNm)
- Option for negative internal clearance

HOIST

- Dual drive available
- 5,000-75,000 lbs (22.2-333.6 kN) line pull
- Smooth or grooved cable drums for wire or synthetic fiber rope
- Static and drum brakes
- Line pull and torque available real time
- Determination of hoist and rope health

SWING DRIVE/GEAR DRIVE

- Both planetary and worm gear options with torque ratings of 375-45,000 ft-lbs (.04-61 kNm)
- Static and dynamic brakes
- Work area definition and angular rotation feedback options

ELECTRONIC MONITORING SYSTEM

- Load moment indicator
- Anti-two block switches – wired or wireless
- Work area indicator
- Drum rotation/last layer indicator
- Torque sensors

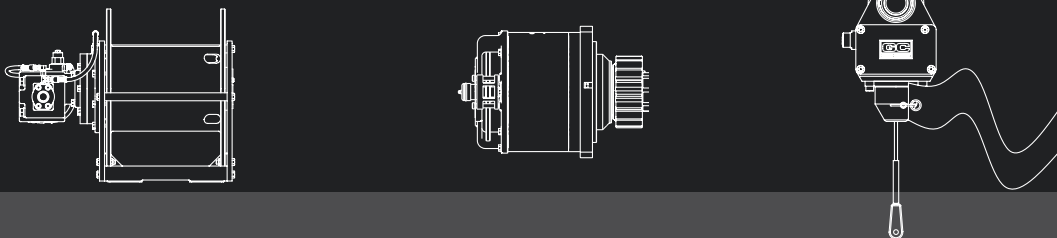

INDUSTRY-LEADING PERFORMANCE AND RELIABILITY.

WINCH

- 1,000-300,000 lbs (4.4 to 1334.4 kN) line pull
- Air, hydraulic, or manual clutch
- Fairleads and cable hold down options

HYDRAULIC PUMP DRIVE

- 15 models with multiple gear ratios
- Up to 1,200 HP (894 kW) and 8 pump pads to SAE standards
- Multiple input options including a torsional coupling

HOIST

- Dual drive available
- 5,000-75,000 lbs (22.2-333.6 kN) line pull
- Smooth or grooved cable drums for wire or synthetic fiber rope
- Static and drum brakes
- Line pull and torque available real time
- Determination of hoist and rope health

SWING DRIVE/GEAR DRIVE

- Both planetary and worm gear options with torque ratings of 375-45,000 ft-lbs (.04-61 kNm)
- Static and dynamic brakes
- Work area definition and angular rotation feedback options

Clearing the way for success

WORKBOAT APPLICATIONS: DREDGE

Reclamation. Excavation. The demanding work of dredges requires equipment that can be trusted to perform consistently and efficiently. Built tough with a heavy-duty design, our products are known for their exceptional reliability and durability for productive and efficient dredging, helping you keep waterways navigable. For dropping spuds, they feature smooth lowering control, high-speed rapid reverse, and free fall. To protect against the elements, our products feature corrosion resistant sealing surfaces, marine grade coatings, and all rotating components are enclosed entirely in an oil bath.

Engineered to reduce downtime and raise productivity, TWG dredge components help ensure projects are completed on time and on budget. Requiring minimal maintenance, they help operators spend more time getting things done, and less time worrying about their equipment. What's more, TWG custom dredge solutions include a wide range of complete, streamlined systems that meet and/or exceed your requirements. Innovative and accurate, our integrated electronic monitoring systems provide real-time interactive updates—allowing dredge operators to work more efficiently and meet critical deadlines

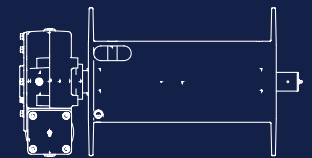
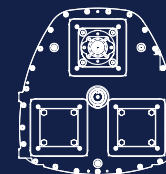
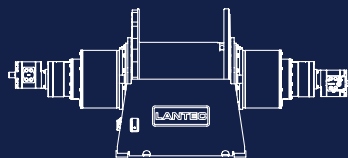

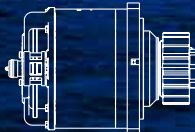

INDUSTRY-LEADING PERFORMANCE AND RELIABILITY.

WINCH

- Braking capacity up to 500,000 lbs (2224.1 kN)
- 1,000-300,000 lbs (4.4 to 1334.4 kN) line pull
- Air, hydraulic, or manual clutch
- Fairleads and cable hold down options

HYDRAULIC PUMP DRIVE

- 15 models with multiple gear ratios
- Up to 1,200 HP (894 kW) and 8 pump pads to SAE standards
- Multiple input options including a torsional coupling

HOIST

- Dual drive available
- 5,000-75,000 lbs (22.2-333.6 kN) line pull
- Smooth or grooved cable drums for wire or synthetic fiber rope
- Static and drum brakes
- Line pull and torque available real time
- Determination of hoist and rope health

Grace under pressure

WORKBOAT APPLICATIONS: BARGE & TUGBOAT

When it comes to moving heavy loads, you need a manufacturing partner known for powerful, high performance products and solutions that get the job done. From heavy-duty components, to innovative technology, TWG is your single source for quality barge and tugboat solutions that deliver optimal performance and long, trouble-free service. Whether transporting materials for a construction project, or maneuvering a ship through complex river systems, our products will enhance your mobility and flexibility, and aid you in positioning.

Engineered to withstand harsh conditions and perform under pressure, our products feature corrosion resistant sealing surfaces, marine grade coatings, and rotating components that are totally enclosed in an oil bath. In addition, our constant tension winches reduce damage to the drum and ensure that loads are not lost during rough seas.

To meet your specific requirements, we offer a wide range of custom solutions. These include multiple drum sizes, free fall and rapid reverse features, plus many complete, streamlined systems, such as electronic monitoring with our mobile app—providing constant feedback and 24/7 access to technical assistance and drawings.

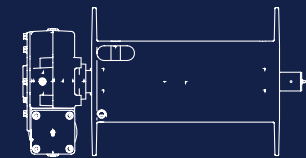
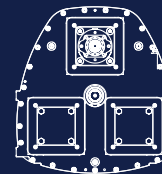
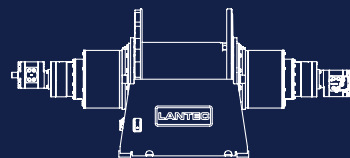



INDUSTRY-LEADING PERFORMANCE AND RELIABILITY.

SLEWING RING BEARING

- Single and double row ball bearings up to 6 ft (1.8 m) diameter
- Bending moment capacity up to 3 M ft-lbs (4 MNm)
- Option for negative internal clearance

HYDRAULIC PUMP DRIVE

- 15 models with multiple gear ratios
- Up to 1,200 HP (894 kW) and 8 pump pads to SAE standards
- Multiple input options including a torsional coupling

SWING DRIVE/GEAR DRIVE

- Both planetary and worm gear options with torque ratings of 375-45,000 ft-lbs (.04-61 kNm)
- Static and dynamic brakes
- Work area definition and angular rotation feedback options

WINCH

- 1,000-300,000 lbs (4.4 to 1334.4 kN) line pull
- Air, hydraulic, or manual clutch
- Fairleads and cable hold down options

King of the swamp

WORKBOAT APPLICATIONS: AMPHIBIOUS EQUIPMENT

Amphibious equipment operates in challenging terrain, including remote marshes and swamps, that is difficult to maneuver and damaging to your equipment. Built tough, TWG amphibious products are optimized for a wide range of severe environments and conditions—including snow in the arctic tundra, rain, mud, water, and extreme heat and cold. With a robust, heavy-duty design for maximum durability, our products allow for better equipment stability, flotation, and ease of 360-degree rotation—along with a climbing ability with the lowest ground pressure, making the impassable possible.

At TWG, our dedicated team of experts can provide you with a customized system package—a complete, streamlined solution that will meet your exact requirements and needs. As the only manufacturer offering total, integrated solutions, we also offer smart electronic monitoring systems that deliver immediate, 24/7 feedback. In addition, operators get instant access to technical assistance and drawings through the TWG mobile app—giving them more control over their equipment at all times.

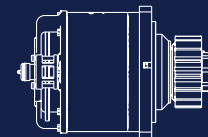
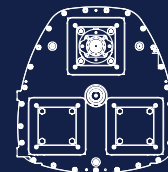
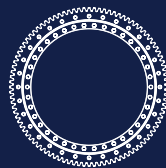

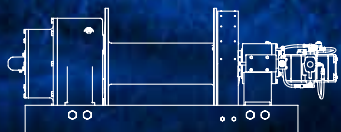

INDUSTRY-LEADING PERFORMANCE AND RELIABILITY.

WINCH

- 1,000-300,000 lbs (4.4 to 1334.4 kN) line pull
- Air, hydraulic, or manual clutch
- Fairleads and cable hold down options

HYDRAULIC PUMP DRIVE

- 15 models with multiple gear ratios
- Up to 1,200 HP (894 kW) and 8 pump pads to SAE standards
- Multiple input options including a torsional coupling

SLEWING RING BEARING

- Single and double row ball bearings up to 6 ft (1.8 m) diameter
- Bending moment capacity up to 3 M ft-lbs (4 MNm)
- Option for negative internal clearance

HOIST

- Dual drive available
- 5,000-75,000 lbs (22.2-333.6 kN) line pull
- Smooth or grooved cable drums for wire or synthetic fiber rope
- Static and drum brakes
- Line pull and torque available real time
- Determination of hoist and rope health

SWING DRIVE/GEAR DRIVE

- Both planetary and worm gear options with torque ratings of 375-45,000 ft-lbs (.04-61 kNm)
- Static and dynamic brakes
- Work area definition and angular rotation feedback options

ELECTRONIC MONITORING SYSTEM

- Load moment indicator
- Anti-two block switches – wired or wireless
- Work area indicator
- Drum rotation/last layer indicator
- Torque sensors

Call in the reinforcements

WORKBOAT APPLICATIONS: OFFSHORE SUPPORT VESSEL

Whether transporting equipment to remote locations or loading and unloading supplies, offshore support vessels need to handle a variety of tasks—on time and on demand, without fail. At TWG, we provide equipment manufacturers with tough, reliable products and components that meet the challenge. Able to handle extreme temperatures, salt water, and long hours, our products deliver maximum results with minimal interruptions. Purpose-built for the marine industry, TWG products also feature corrosion resistant sealing surfaces, marine grade coatings, and all rotating components are totally enclosed in an oil bath to ensure a long, productive life.

Known for durability and trouble-free service, our model lines offer smooth lowering control, fast line speed, and rapid reverse—so operators can work faster, more efficiently, and meet key deadlines. Delivering superior performance, our crane components meet OSHA requirements for both wired and wireless applications, while our hoists can be custom designed for your needs and API, ABS, and DNV requirements. Our fully integrated solutions include complete winch systems with ROV support, launch and recovery systems (LARS), and dive support systems with umbilical winches. No matter your needs, we'll make sure you get the best, most streamlined solution possible. And to keep things moving smoothly, our advanced, interactive electronic monitoring systems provide real-time updates and technical assistance 24/7, giving equipment operators a new level of control and accuracy.

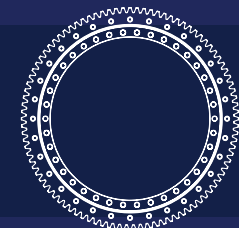
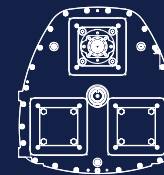
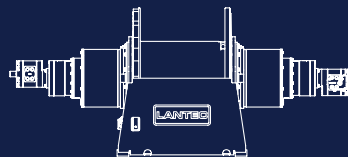

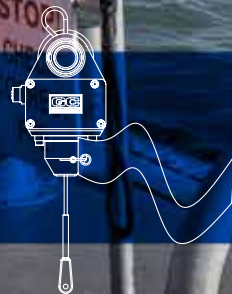
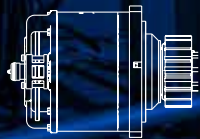
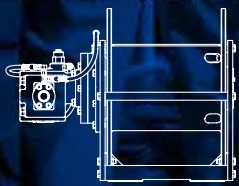

dovertwg.com

YOUR

New horizons

With a proud legacy behind us, we're taking bold steps toward the future—embracing change with disruptive technology that provides interactive smart solutions and expands possibilities.

Nimble and forward thinking, TWG is the innovative partner you need to optimize efficiency, reduce waste, and revolutionize your product lines. Our customizable solutions give you a competitive advantage by unleashing new levels of performance and interactivity—leveraging advanced Artificial Intelligence and the Industrial Internet of Things.

Our customer-focused team of application experts approaches your business needs with a solutions-driven mindset. When you work with TWG and Dover Corporation, you're partnering with companies that have a strong global footprint and are committed to providing insightful solutions to our partners. Together, the sky is the limit.



OUR MODEL LINES

TWG has facilities located in Jenks, OK, USA; Surrey, BC, Canada; and Bangalore, India. We are comprised of seven model lines that specialize in industry-specific products.

DP Winch: planetary winches for commercial and government equipment serving the towing and recovery markets

Gear Products: planetary and worm gear winches, swing drives, slewing ring bearings, hydraulic pump drives, and rotators for trucks, cranes, and heavy equipment serving the utility, construction, forestry, marine, and mining markets

Greer: load moment indicators, anti-two block systems, angular rotation feedback, and drum rotation indicators for lattice and telescopic boom cranes

LANTEC: planetary winches, hoists, and gear reducers

Pullmaster: planetary winches for commercial fishing boats, caisson drilling equipment, pipe layers, tractor/skidlers, and dredges

Tulsa Winch: planetary and worm gear winches and swing drives for large oilfield trucks, heavy haul tractor packages, digger derricks, cranes, and aerial work platforms

RUFNEK: planetary and worm gear winches, rotating mousehole, rotary table drives, and coiled tube injector heads for oilfield equipment



LANTEC®

PullMASTER



dovertwg.com

Product options

WINCHES

| | OPTION | LINE PULL (k LBS) | LINE PULL (kN) |
|------------------|----------------------------------|-------------------|--------------------|
| PLANETARY | Single drive | 1 to 200 k | 4.4 to 889.6 kN |
| | Dual drive | 35 to 300 k | 155.6 to 1334.4 kN |
| | Free spool - manual | 3 to 45 k | 13.3 to 200.1 kN |
| | Free spool - pneumatic/hydraulic | 3 to 130 k | 13.3 to 578.2 kN |
| | Cable hold down - spring | 3 to 15 k | 13.3 to 66.7 kN |
| | Cable hold down - pneumatic | 25 to 100 k | 111.2 to 444.8 kN |
| | Drum pressure roller | 1 to 300 k | 4.4 to 1334.4 kN |
| | Ratchet & pawl | 12 to 300 k | 53.3 to 1334.4 kN |
| | Drum band brake | 12 to 300 k | 53.3 to 1334.4 kN |
| | Controlled free fall | 2 to 50 k | 8.8 to 222.4 kN |
| | Rapid reverse | 4 to 85 k | 17.7 to 378.0 kN |
| | Fairlead | 3 to 45 k | 13.3 to 200.1 kN |
| | Capstan head | 8 to 30 k | 35.5 to 133.4 kN |
| | Bumper package | 8 to 30 k | 35.5 to 133.4 kN |
| | Traction | 7 to 35 k | 31.1 to 155.6 kN |
| WORM | Mechanical input | 10 to 130 k | 44.4 to 578.2 kN |
| | Hydraulic input | 10 to 130 k | 44.4 to 578.2 kN |
| | Adjustable worm brake | 10 to 130 k | 44.4 to 578.2 kN |
| | Kick-out - manual | 10 to 130 k | 44.4 to 578.2 kN |
| | Kick-out - pneumatic/hydraulic | 10 to 130 k | 44.4 to 578.2 kN |
| | Drum band brake | 10 to 130 k | 44.4 to 578.2 kN |

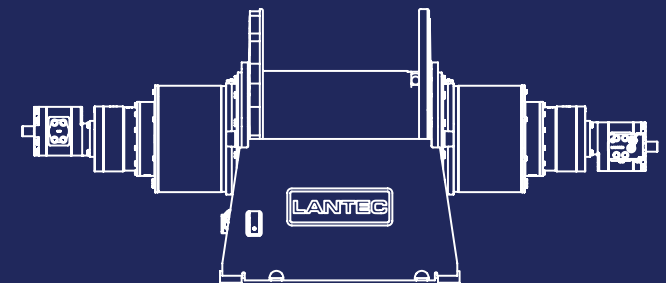

HOISTS

| | OPTION | LINE PULL (k LBS) | LINE PULL (kN) |
|------------------|-----------------------|-------------------|------------------|
| PLANETARY | Single drive | 1 to 75 k | 4.4 to 333.6 kN |
| | Dual drive | 20 to 70 k | 88.9 to 311.3 kN |
| | Free spool | 3 to 50 k | 13.3 to 222.4 kN |
| | Drum pressure roller | 5 to 70 k | 22.2 to 311.3 kN |
| | Ratchet & pawl | 12 to 70 k | 53.3 to 311.3 kN |
| | Drum band brake | 12 to 70 k | 53.3 to 311.3 kN |
| | Controlled free fall | 2 to 50 k | 8.8 to 222.4 kN |
| | Rapid reverse | 4 to 50 k | 17.7 to 222.4 kN |
| WORM | Hydraulic input | 5 to 20 k | 22.2 to 88.9 kN |
| | Adjustable worm brake | 5 to 20 k | 22.2 to 88.9 kN |

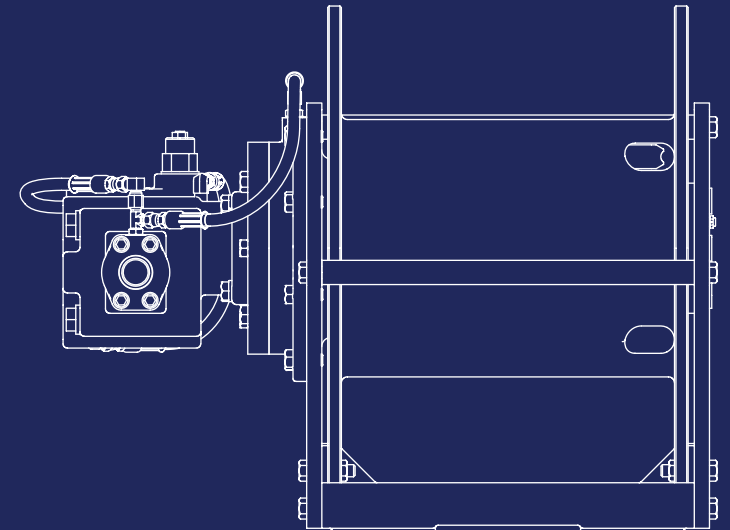

Product options

SWING DRIVE/GEAR DRIVE

| | OPTION | CONTINUOUS OUTPUT (k IN-LBS) | CONTINUOUS OUTPUT (kNm) |
|------------------|---------------------------------------|---------------------------------|----------------------------|
| PLANETARY | Static brake | 15 to 540 k | 1.7 to 61 kNm |
| | Dynamic brake | 20 to 125 k | 2.3 to 14.1 kNm |
| | Gear ratio 6 to 8 | 15 to 40 k | 1.7 to 4.5 kNm |
| | Gear ratio 15 to 27 | 15 to 40 k | 1.7 to 4.5 kNm |
| | Gear ratio 35 to 41 | 15 to 65 k | 1.7 to 7.3 kNm |
| | Gear ratio 42 to 51 | 15 to 125 k | 1.7 to 14.1 kNm |
| | Gear ratio 64 to 71 | 15 to 195 k | 1.7 to 22 kNm |
| | Gear ratio 135 to 140 | 539 k | 61 kNm |
| | Square mounting flange | 15 to 52 k | 1.7 to 5.9 kNm |
| | Rectangular mounting flange | 30 to 125 k | 3.4 to 14.1 kNm |
| | Round mounting flange | 40 to 539 k | 4.5 to 61 kNm |
| | Custom mounting flange | 180 to 250 k | 20.3 to 28.3 kNm |
| WORM | Eccentric ring | 15 to 125 k | 1.7 to 14.1 kNm |
| | Static brake | 3 to 220 k | 0.3 to 24.9 kNm |
| | Gear ratio 10 to 15 (backdrivable) | 30 to 40 k | 3.4 to 4.5 kNm |
| | Gear ratio 30 to 54 | 3 to 220 k | 0.3 to 24.9 kNm |
| | Flange mount | 10 to 36 k | 1.1 to 4 kNm |
| | Upright mount | 15 to 220 k | 1.7 to 24.9 kNm |
| | Low mount | 3 to 58 k | 0.3 to 6.5 kNm |
| | Eccentric ring | 5 to 40 k | 0.5 to 4.5 kNm |

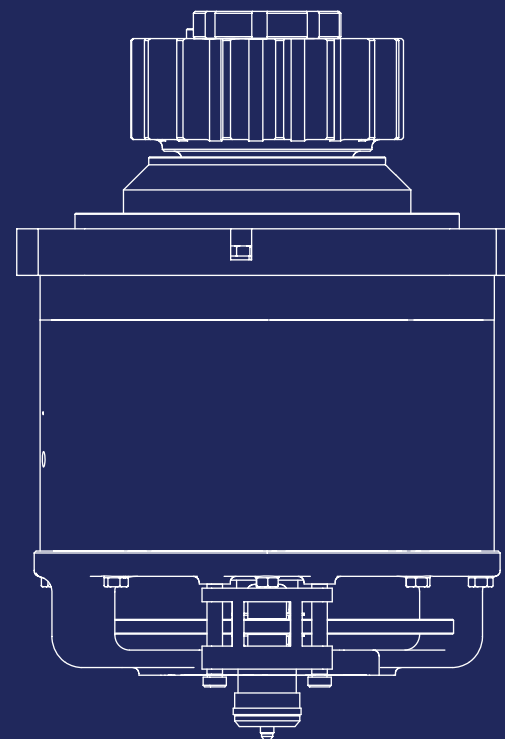

SLEWING RING BEARINGS AND HYDRAULIC PUMP DRIVES

| | OPTION | BENDING MOMENT CAPACITY (k FT-LBS) | BENDING MOMENT CAPACITY (kNm) |
|------------------------------|---------------------|------------------------------------|-------------------------------|
| SLEWING RING BEARINGS | External gear teeth | 1 to 3000 k | 1.3 to 4000 kNm |
| | Internal gear teeth | 1 to 2000 k | 1.3 to 2700 kNm |
| | No gear teeth | 1 to 3000 k | 1.3 to 4000 kNm |
| | Single row ball | 1 to 2500 k | 1.3 to 3400 kNm |
| | Double row ball | 5 to 3000 k | 6.5 to 4000 kNm |

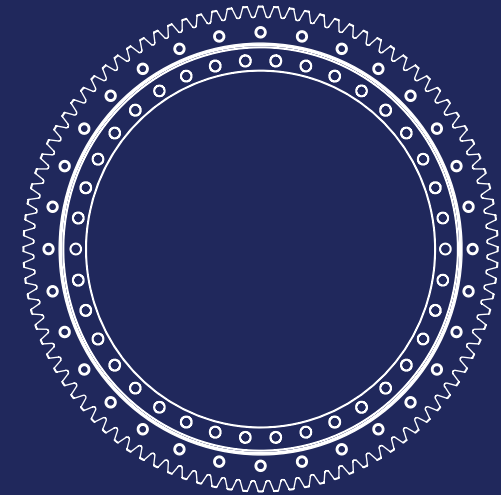

| | OPTION | INPUT TORQUE CAPACITY (k FT-LBS) | INPUT TORQUE CAPACITY (kNm) |
|------------------------------|------------|----------------------------------|-----------------------------|
| HYDRAULIC PUMP DRIVES | Single pad | 0.7 to 2 k | 1 to 2.7 kNm |
| | 2 pad | 0.8 to 2.2 k | 1.1 to 3 kNm |
| | 3 pad | 1.2 to 2.2 k | 1.6 to 3 kNm |
| | 4 pad | 2.1 to 2.5 k | 2.8 to 3.4 kNm |
| | 5 pad | 2.2 k | 3 kNm |
| | 6 pad | 2.2 to 3.5 k | 2.9 to 4.7 kNm |
| | 8 pad | 2.1 to 2.5 k | 2.8 to 3.4 kNm |

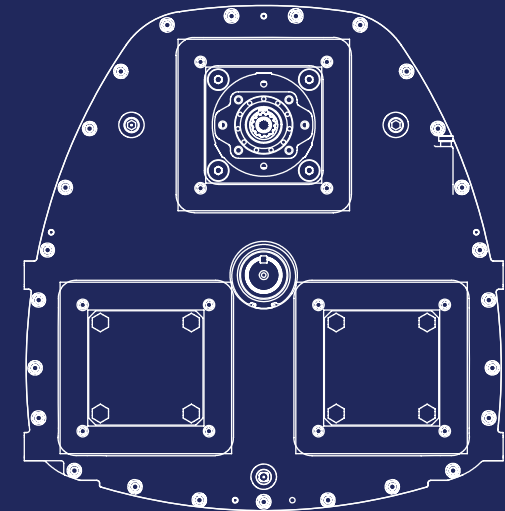

Product options

ELECTRONIC MONITORING SYSTEMS

| | OPTIONS | ATTRIBUTES |
|---|-------------------------|--|
| LOAD MOMENT INDICATORS | Display options | Greer Element II - 7" (177 mm) Insight - 4.3" (109 mm) |
| | Resolution | Greer Element II - WVGA, 800 x 400 pixels, 16-bit color Insight - WQVGA, 480 x 272 pixels, 16-bit color |
| | Communications | CAN 2.0B according to ISO-11898-2, J1939 protocol |
| | Anti-two block switches | Wired or wireless |
| | Reeling drum | Boom extensions of 35, 90, 110 and 200 feet (10.6 m, 27.2 m, 33.3 m and 60.5 m) |
| | Work area indicator | Absolute encoder, sensing rotation without power up to 360 degrees (CW or CCW) from home |
| DRUM ROTATION/ LAST LAYER INDICATORS | Operating voltage | 9-32 VDC, reverse polarity protected |
| | IP ratings | IP67 |
| | Communications | CAN 2.0B according to ISO-11898-2, J1939 protocol |
| | System voltage | Supports 12 and 24 volt systems |
| | Lifetime | Logs lifetime drum rotation |

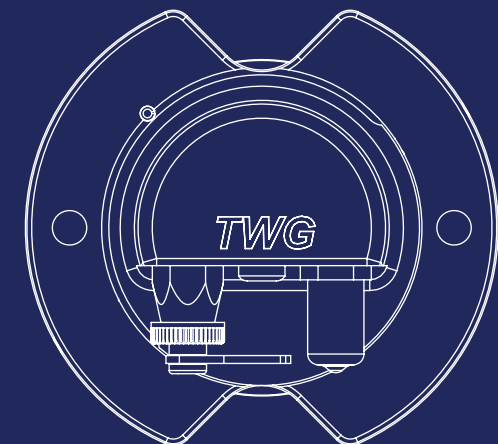
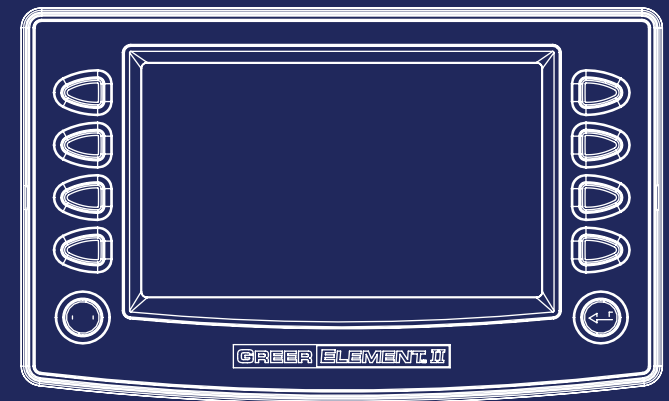

MOBILE APP

Get real-time technical support 24 hours a day through our website and mobile app, complete with voice recognition for quick, easy use, and access to over 10,000 documents. You can also monitor up to 500 sensors, use GSM, and monitor your equipment from any web portal, mobile phone, or tablet.

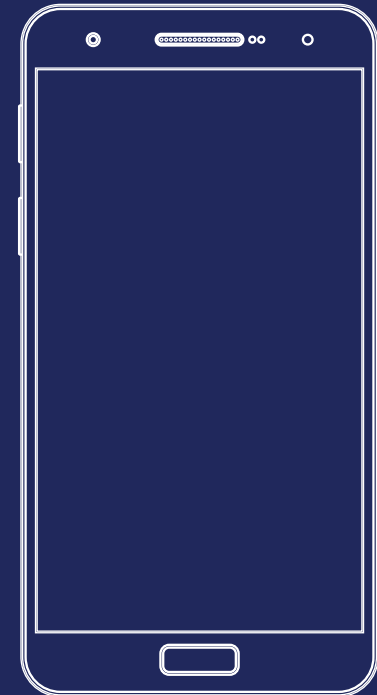

Contact Us:

11135 S. James Avenue
Jenks, OK 74037 USA
918-298-8300
dovertwg.com

